

- Linear steady state characteristic
- Integrated hydraulic accumulator
- Safe to run dry
- Self-priming up to 4 metres depth
- Liquid fertiliser proof



**P120**

Capacity in litres at 5 bar: 120 litres/min.  
 Nominal speed: 540 rpm  
 Continuous pressure: 15 bar  
 Maximum pressure: 20 bar  
 Speed range: 450-700 rpm  
 Spline shaft: DIN 9611 / ISO 500  
 Standard working diaphragm: 2 x NBR  
 Accumulator diaphragm: 2 x NBR  
 Inlet-ø suction side: AS40  
 Outlet-ø pressure side: AS30  
 Lubrication: Oil bath  
 Weight: 13,2 kg

Material: Cast aluminium, partially anodised and coated with epoxy resin, POM, Stainless steel:1.4305, NBR seals

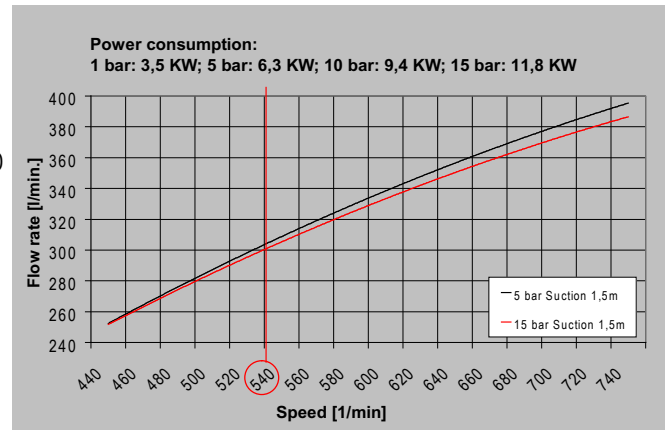

Pump variants (Example)	
Article-No.	Type
82027	Kolbran pump P120 with bracket and implement input connection shields Inlet: Opposite drive Outlet: Opposite drive
More variations on request	

A [mm]	B [mm]	C [mm]	E <sub>min</sub> [mm]	E <sub>max</sub> [mm]	F [mm]
230	270	365	33	217	M12

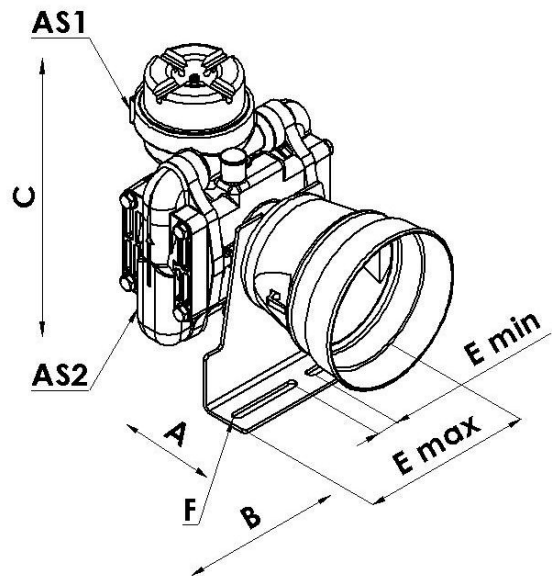

Recommended fittings inlet (AS2)		Recommended fittings outlet (AS1)	
Article-No.	Type	Article-No.	Type
17409	Plug-in hose tail AS40/ø46 cpl	33793	Plug-in hose tail AS30/ø33/90° cpl
08275	Plug-in hose tail AS40/ø39/90° cpl	81119	Plug-in hose tail AS30/ø25 cpl
06247	Plug-in hose tail AS40/ø39 cpl	01399	Plug-in hose tail AS30/ø33 cpl

**Special types:**

- Viton® - working diaphragms
- Desmopan® - working diaphragms
- Oil-filling ex-works on request
- Hollow shaft for Hydromotors
- Hydromotor